

PRODUCT DATASHEET

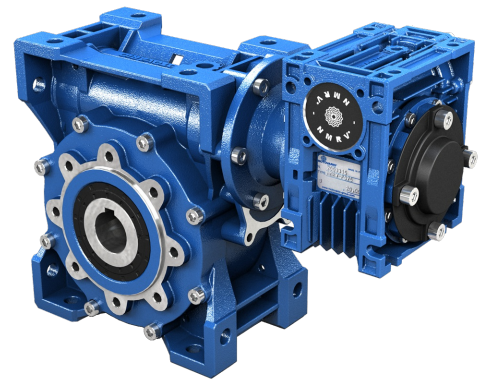

COMBINED WORM GEARED MOTOR WITH ACCESSORIES/MOTOR

DATE 17.05.2018

CONFIGURATION

| CHARACTERISTIC | VALUE |
|------------------------------|---------------------------------|
| Motor/Inverter Motor | With Motor |
| Regulations | No |
| Combined Worm | PAM NMRV/NMRV Power |
| Size | O30/O63 |
| Ratio (i1xi2) | 1800(30x60) |
| Input Dim. | Ø90x11 (IEC63 B14) |
| Connection (Worm Wheel-PAM) | Ø14-Ø14 |
| Hollow Output Shaft Dim. | Ø25 |
| Double-Extended Worm Shaft | No |
| 2nd Red. Doub-Ext Worm Shaft | No |
| Execution | BS2 |
| Mounting Position | U |
| Output Flange | No. |
| Output Shaft | No |
| Output Cover | No |
| VI-Output Oil Seal | NBR-Nitrile |
| VI-2nd Red. Output Oil Seal | NBR-Nitrile |
| VI-Input Oil Seal | ACM-Polyacrylate |
| VI-2nd Red. Input Oil Seal | ACM-Polyacrylate |
| VI-Output Bearings | Ball Bearings |
| VI-2nd Red. Output Bearings | Ball Bearings |
| VI-Lubrication | Eni Telium VSF 320 |
| VI-2nd Red. Lubrication | Eni Telium VSF 320 |
| Paint | Ral 5010/Ral 5010 Blue |
| Supplier | Motovario |
| Regulations | CE |
| Motor | Three-Phase |
| Size | O63 |
| Series | Standard Efficiency |
| Poles | 4 |
| Electrical Execution | Std (Voltage Tolerance +/- 10%) |
| Service | S1 |
| Voltage | 220/380V |
| Frequency | 50-60 Hz |
| Power | 0,18-0,21 kW |
| Cooling | Self-Ventilated |
| Mounting Arrangements | B14 |
| Terminal Box | Pos.1 |
| Flange Dim. | Ø90 |
| Shaft Dim. (DE) | Ø11x23 |

| CHARACTERISTIC | VALUE |
|-----------------------|-----------|
| Rear Shaft End (NDE) | No |
| Insulation Rating | F |
| Protection Rating | IP55 |
| Thermal Protectors | No |
| Ambient Conditions | Standard |
| Heaters | No |
| Condensation Drainage | No |
| Devices | No |
| Accessories | None |
| Terminal Box Cover | Aluminium |
| Fan | Plastic |
| Fan Cover | Standard |
| MO-Notes | No |

Values expressed in [mm]

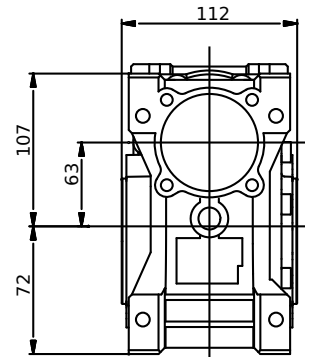
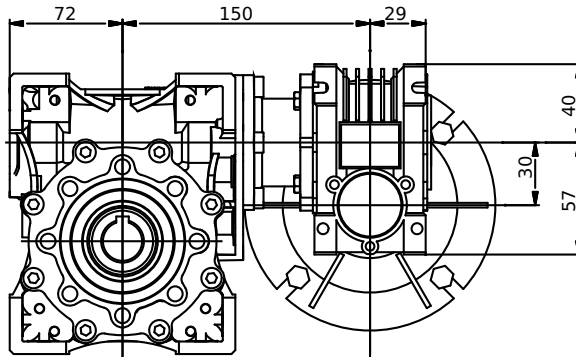
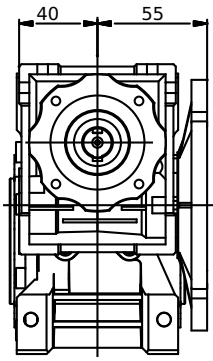

The mounting position of the gear unit identifies its space orientation. B3 mounting position, as from a technical point of view, ensures lower oil splash, better lubrication and less heating.

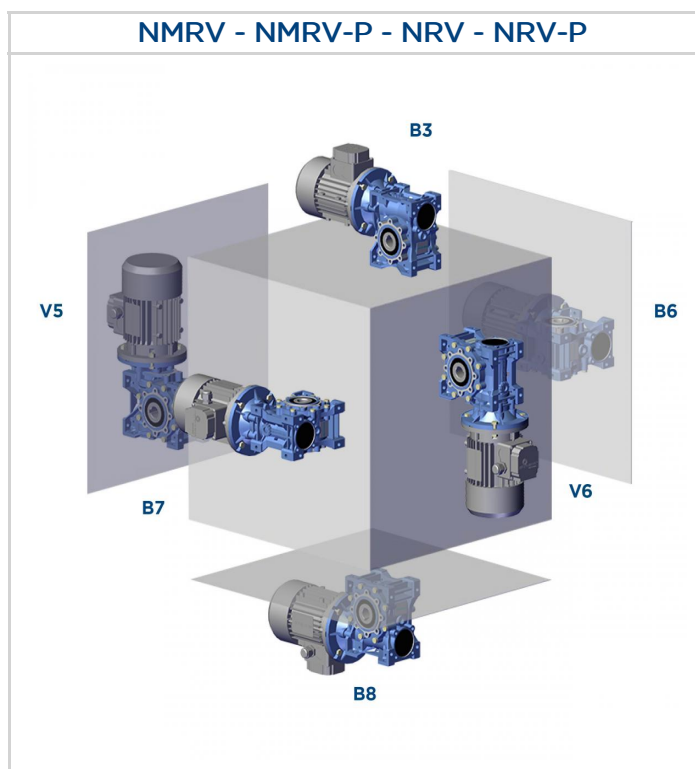

Execution

NMRV/NMRV-P+NMRV/NMRV-P - NRV/NRV-P+NMRV/NMRV-P

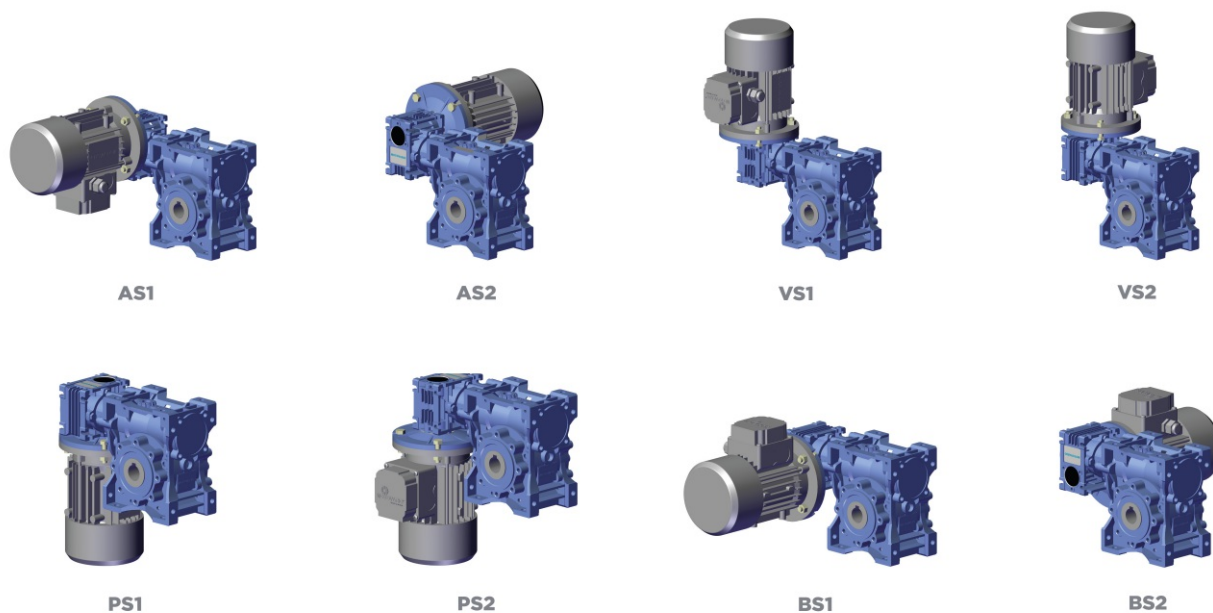

- The gear reducers size 025 - 030 - 040 - 050 - 063 - 075 - 090 - 105 - 110 - 130 - 150 are supplied complete with lubricant for life, synthetic oil, ENI TELIUM VSF. They can be mounted in any position envisaged in the catalogue, except for NMRV 090 - 110 and NRV 075-090-110 for which you must to specify the mounting position.
- For sizes 130 and 150 it is necessary to specify the position, otherwise the gear reducers are supplied with the quantity of oil relating to pos. B3.
- Only reduction units 130 and 150 are fitted with breather, level and oil drainage plugs.
- The pre-stage helical modules are supplied complete with life-long lubricant, synthetic oil, ENI TELIUM VSF. Lubrication is separated from that of the worm gear reducers.

It is recommended, after installation, to replace the closed plug used for transportation with the supplied breather plug.

Quantity of oil in litres -

| NMRV | 025 | 030 | 040 | 050 | 130 | 150 |
|-------|------|------|------|------|-----|-----|
| B3 | 0,02 | 0,04 | 0,08 | 0,15 | 4,5 | 7 |
| B8 | | | | | 3,3 | 5,1 |
| B6-B7 | | | | | 3,5 | 5,4 |
| V5 | | | | | 4,5 | 7 |
| V6 | | | | | 3,3 | 5,1 |

| NMRV-P | 063 | 075 | 090 | 110 |
|--------|------|------|------|-----|
| B3 | 0,33 | 0,55 | 1,15 | 1,6 |
| B8 | | | | |
| B6-B7 | | | | |
| V5 | | | | |
| V6 | | | | |

| SW | 030 | 040 | 050 | 063 | 075 | 090 | 105 |
|-------|------|------|------|-----|------|-----|-----|
| B3 | 0,04 | 0,08 | 0,15 | 0,3 | 0,55 | 1 | 1,6 |
| B8 | | | | | | | |
| B6-B7 | | | | | | | |
| V5 | | | | | | | |
| V6 | | | | | | | |

| HW | HW030 | | HW040 | |
|-------------------|-----------|-----------|-----------|-----------|
| | NMRV-P063 | NMRV-P075 | NMRV-P090 | NMRV-P110 |
| B3-B6-B7-B8-V5-V6 | 0,06 | 0,09 | 0,11 | 0,12 |

| H | A31 |
|-------|------|
| B3-B5 | 0,07 |

The worm screw rotation is right-handed.

DIRECTION OF ROTATION - HIGH SPEED SHAFT

NMRV - NRV - SW - ISW



MOUNTING POSITION **B3**

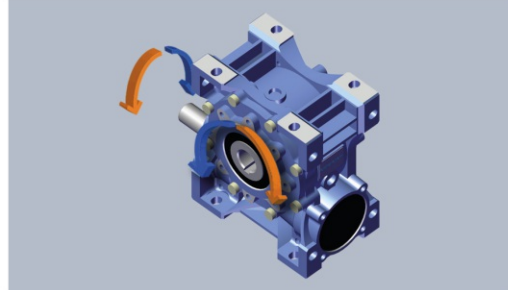

MOUNTING POSITION **B8**

NMRV + NMRV - SW + SW - NRV + NMRV - ISW + SW

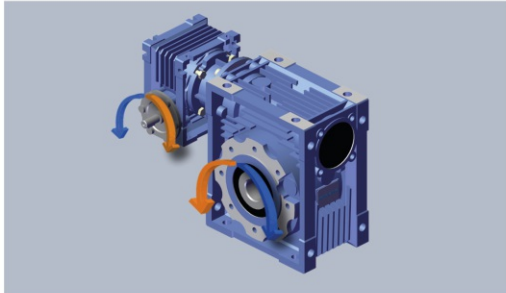

MOUNTING POSITION **AS1**

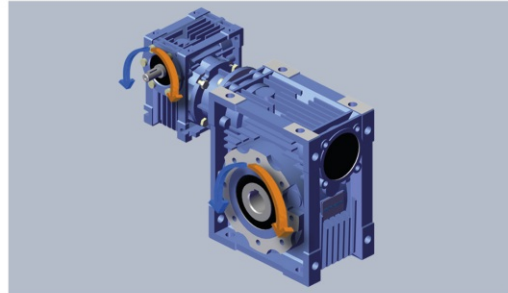

MOUNTING POSITION **BS1**